

Dell Graphics Card

Quick Setup Guide

⚠ WARNING: Before working inside your computer, read the safety information that shipped with your computer. For safety best practices, see the regulatory compliance home page at [Dell.com/regulatory_compliance](https://www.dell.com/regulatory_compliance).

1 Install the graphics card in your computer

Install the graphics card in a PCI-E x16 slot on your computer. For information on opening the computer cover, location of the slot, and installing the graphics card, see the *Service Manual* or *Owner's Manual* of your computer at [Dell.com/support/manuals](https://www.dell.com/support/manuals).

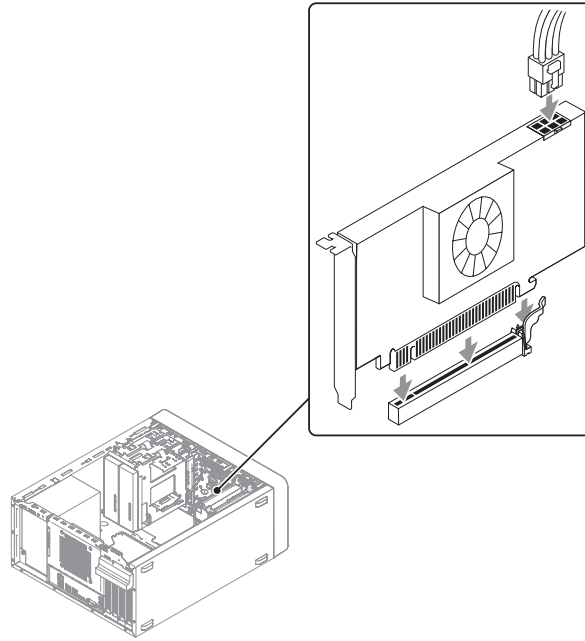

NOTE: The type and number of power cables that you need to connect to the card may vary depending on the card you purchased.

2 Download and install the drivers for your graphics card

1. Go to [Dell.com/support](https://www.dell.com/support).
2. Click **Product support**.
3. Click **View products** → **Electronics & Accessories** → **Graphics Card** and select your graphics card.
4. Click **Drivers & downloads**.
5. Select the operating system installed on your computer.
6. Scroll down the page and expand **Video**.
7. Under your graphics-card model, click **Download File** and save the file.
8. After the download is complete, open the file and follow the instructions on the screen to install the drivers.

Product support and manuals

Contact Dell

Regulatory and safety

Dell.com/support

Dell.com/contactdell

Dell.com/regulatory_compliance

Safety, Environmental, and Regulatory Information

Recycling Information

Dell recommends that customers dispose of their used computer hardware, monitors, printers, and other peripherals in an environmentally sound manner. Potential methods include reuse of parts or whole products and recycling of products, components, and/or materials. For specific information on Dell's worldwide recycling programs, see www.dell.com/recycle.

Waste Electrical and Electronic Equipment (WEEE) Directive



In the European Union, this label indicates that this product should not be disposed of with household waste. It should be deposited at an appropriate facility to enable recovery and recycling. For information on how to recycle this product responsibly in your country, please visit: www.dell.com/recycle.

Safety and Regulatory Information

You can find additional recommended Product Safety Best Practices and Regulatory Compliance information on Accessibility, Communications Devices (Radio and Modem), Electromagnetic Compatibility (EMC), Electrostatic Shock (ESD), Energy, Environmental (REACH and RoHS), Ergonomics, Material Safety (MSDS), Transportation, and TV Tuners on the Regulatory Compliance webpage, www.dell.com/regulatory_compliance.

Terms of Sale

PLEASE READ THIS DOCUMENT CAREFULLY! IT CONTAINS THE TERMS OF SALE THAT GOVERN YOUR PURCHASE, UNLESS YOU HAVE A SEPARATE AGREEMENT WITH DELL. THIS DOCUMENT CONTAINS VERY IMPORTANT INFORMATION ABOUT YOUR RIGHTS AND OBLIGATIONS, AS WELL AS LIMITATIONS AND EXCLUSIONS THAT MAY APPLY TO YOU. THIS DOCUMENT ALSO CONTAINS A BINDING ARBITRATION CLAUSE.

Important Notice

Your purchase and use of this product is subject to and governed by Dell's applicable Terms of Sale.

If you are a consumer customer and you purchased directly from Dell, your purchase is governed by the U.S. Consumer Terms of Sale at www.dell.com/consumerters.

Para obtener una versión en español de las condiciones de venta, visite www.dell.com/condicionesdecompra.

If you are a consumer customer and you purchased through a retail store, your purchase is governed by the Retail Purchaser End User Agreement at www.dell.com/retailagreement.

YOUR AGREEMENT WITH DELL CONTAINS VERY IMPORTANT INFORMATION ABOUT YOUR RIGHTS AND OBLIGATIONS, AS WELL AS LIMITATIONS AND EXCLUSIONS. THE AGREEMENT REQUIRES THE USE OF ARBITRATION ON AN INDIVIDUAL BASIS TO RESOLVE DISPUTES, and where applicable, specifies arbitration INSTEAD OF JURY TRIALS OR CLASS ACTIONS. PLEASE REVIEW THE TERMS CAREFULLY.

Unless you have a separate written agreement with Dell that specifically applies to your order, if you are a commercial customer and you purchased this product directly from Dell for your internal use, your purchase is governed by the Commercial Terms of Sale: www.dell.com/CTS.

For the avoidance of doubt, to the extent that Dell is deemed under applicable law to have accepted an offer by you: (a) Dell hereby objects to and rejects all additional or inconsistent terms that may be contained in any purchase order or other documentation submitted by you in connection with your order; and (b) Dell hereby conditions its acceptance on your assent that the foregoing terms and conditions shall exclusively control.

IF YOU DO NOT AGREE WITH THESE TERMS, DO NOT USE YOUR PRODUCT AND RETURN IT TO DELL IN ACCORDANCE WITH DELL'S RETURN POLICY LOCATED AT www.dell.com/returnpolicy.

About Dell's Limited Hardware Warranty

Download or print Dell's Limited Hardware Warranty at www.dell.com/warranty or call to request a hard copy of the Limited Hardware Warranty: 1-877-884-3355.

What if I purchased a service contract?

If your service contract is with Dell or if you purchased a service contract through us with a third-party service provider you may download or print it from www.dell.com/servicecontracts.



04NP33A00

Printed in China.

2015-06